

INSTRUCTION MANUAL
FOR
MODEL 418 RC OSCILLATOR

KIKUSUI ELECTRONICS CORP., JAPAN

TABLE OF CONTENTS

	<u>PAGE</u>
1. GENERAL	1
2. SPECIFICATIONS	2
3. OPERATING PROCEDURE	4
3.1 EXPLANATION OF PANEL CONTROLS AND SWITCHES	4
3.2 OPERATING PROCEDURE	5
3.3 PRECAUTIONS	6
4. OPERATING PRINCIPLE	8
5. MAINTENANCE	10
5.1 CHASSIS INSPECTION	10
5.2 ADJUSTMENTS	11
* SCHEMATIC CIRCUIT DIAGRAM	

1. GENERAL

The Model 418 RC Oscillator employs a solid-state Wien bridge which oscillates at 10 Hz - 1 MHz in five ranges. Being incorporated with a thermistor amplitude control circuit, the Oscillator provides a sine wave with very minor output voltage variation against switching of the frequency range selector and turning of the frequency dial. Since no output voltage readjustment accompanying frequency range switching is required, the Oscillator is very convenient in actual use.

The Oscillator incorporates a square wave generator circuit (Schmitt circuit) which provides a square waveform with a fast rise time.

The output voltage level is adjustable for a very wide range through combined use of a continuously variable attenuator and a -20 dB stepwise attenuator.

2. SPECIFICATIONS

Power requirements:	----- V, 50/60 Hz, approx. 6 VA
Weight:	Approx. 2 kg
Dimensions:	110 W × 140 H × 252 D mm
(Maximum dimensions):	(110 W × 115 H × 312 D mm)
Ambient temperature:	5°C to 35°C
Oscillation frequency:	10 Hz - 1 MHz, in 5 ranges
Frequency ranges:	X10 10 - 100 Hz X100 100 - 1000 Hz X1 k 1 k - 10 kHz X10 k 10 k - 100 kHz X100 k ... 100 k - 1 MHz
Frequency accuracy:	±(3% + 1 Hz)
Output impedance:	600 Ω ±10%
Output attenuator:	Continuously variable control plus (0 dB)/(-20 dB) selector buttons
Output voltage/ frequency characteristics:	Within ±0.5 dB (1 kHz reference, 600 Ω load)
Output terminal:	12/16, 5-way type, 19 mm (3/4 in.) distance
output waveform:	Sine wave and square wave
Sine wave (at maximum output voltage):	
Output voltage:	4 V rms or over (with 600 Ω load, at 25°C)
Distortion factor:	10 - 30 Hz 2% or less 30 - 100 Hz 1% or less 100 - 1 kHz 0.5% or less 1 k - 100 kHz 0.3% or less 100 k - 500 kHz ... 1% or less

Square wave (at maximum output voltage):

Output voltage: 8 Vp-p or over (600 Ω load)

Rise time: 0.2 μ sec or faster

Overshoot: 2% or less

Sag: 5% or less (at 50 Hz)



Accessories: Instruction manual 1 copy

3. OPERATING PROCEDURE

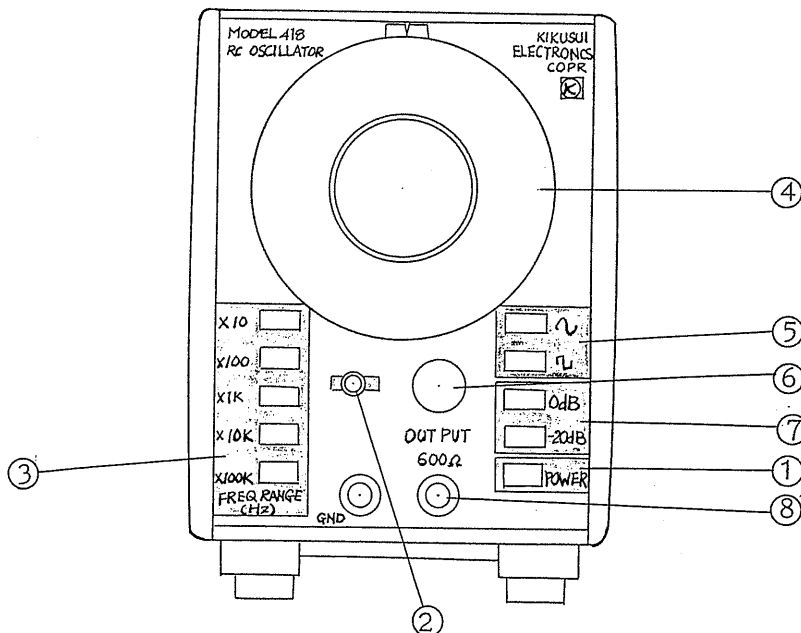

3.1 EXPLANATION OF PANEL CONTROLS AND SWITCHES



- (1) **POWER:** The main power switch. Depressed state is for power on. Pressing again the switch resets it to the popped up state or the power off state.
- (2) **Power pilot lamp:** Lights when the power is on. The lamp actually is a light emitting diode and is free from filament failure unlike the incandescent pilot lamp.
- (3) **FREQ RANGE (Hz):** Frequency range selector pushbuttons. The dial reading multiplied by the factor selected by the corresponding button denotes the oscillating frequency.



- (4) FREQ DIAL: For continuous variation (up to 10 times) of the oscillating frequency.
- (5)  and : Buttons to select either sine wave or square wave output. The output waveform conforms with the depressed button.
- (6) OUTPUT CONTROL: For continuously-variable adjustment of output voltage which increases as this control is turned clockwise.
- (7) 0 dB, -20 dB: Selects the factor to be multiplied to the level adjusted by OUTPUT CONTROL (6).
- (8) OUTPUT (600 Ω): The output binding-post terminals. The black terminal (GND terminal) is grounded to the chassis.

3.2 OPERATING PROCEDURE

- (1) Turning on the power: Press the power switch. The pilot lamp (light emitting diode) will turn on and the Oscillator will become the stabilized oscillating state within a few seconds.
- (2) Setting the oscillation frequency:
Set the oscillation frequency with the FREQ RANGE selector and the FREQ dial. The oscillation frequency is determined by the FREQ dial reading multiplied by the factor selected by the FREQ RANGE selector.
- (3) Output waveform selection:
Press the  button or  button for a sine wave output or a square wave output, respectively.

- (4) Output voltage setting: Adjust the output voltage with the OUTPUT CONTROL. The output voltage increases as this control is turned clockwise. To decrease the output voltage by a factor of -20 dB, depress the -20 dB button.

3.3 PRECAUTIONS

- (1) Ambient temperature must be 5°C to 35°C. Note, however, that even when ambient temperature is below 40°C, the internal temperature of the Oscillator may become abnormally high if the Oscillator is exposed to direct sunlight or other heat source.
- (2) Since a thermistor is employed as the oscillation voltage control element, the output voltage is affected by ambient temperature. If a constant output voltage is required for a long period, check the output voltage with a voltmeter at appropriate intervals.
- (3) The input impedance of the instrument to be connected to the OUTPUT terminal of the Oscillator must match with the output impedance (600 Ω) of the Oscillator. Note that the specified output voltage/frequency characteristics may become unattainable if the specified load condition is not observed due to long lead wires or other adverse situations.
- (4) The rate of overshoot may increase when the square wave output voltage is small. To obtain better waveform, it is recommendable to operate the Oscillator with as large output voltage as possible.
- (5) Avoid using the Oscillator in dusty environment or highly humid atmosphere.
- (6) The Oscillator does not properly operate if two or more buttons of the FREQ RANGE selector, waveform selector ( or ) , or output

attenuation selector (0 dB or -20 dB) are simultaneously depressed. The same applies also when none of any one of these selectors are pressed. One button of each selector must be pressed.

4. OPERATING PRINCIPLE

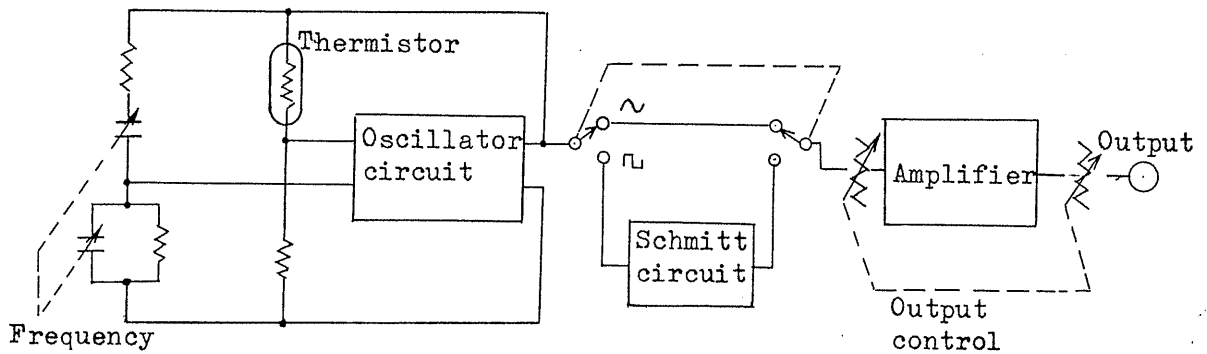

Fig. 1 Block diagram of the 418 Oscillator

Among low frequency oscillators, RC oscillators which employ R and C as frequency-determining elements are most common. Among RC oscillators, Wien bridge type is most popular. The Wien bridge has many advantages over other oscillation circuits. Its frequency is easily variable, and it operates stably and provides an output signal waveform with very small distortion. The Model 418 RC Oscillator also employs a Wien bridge circuit. The operating principle of the Wien bridge oscillator circuit is shown in Fig. 2.

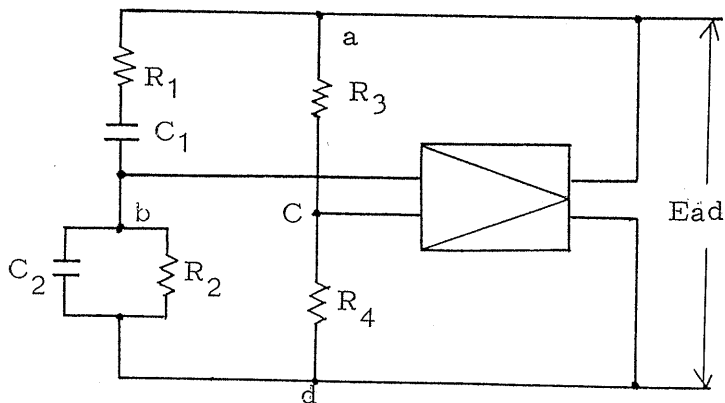

Fig. 2 Wien bridge oscillator circuit

Referring to Fig. 2, the phase of Ebc becomes the same with that of Ead when the below condition is satisfied.

$$f = \frac{1}{2\pi\sqrt{R_1 R_2 C_1 C_2}} \dots\dots\dots (1)$$

The circuit oscillates when the below condition is satisfied.

$$E_{bc} = \left(\frac{1}{1 + \frac{R_1}{R_2} + \frac{C_2}{C_1}} - \frac{R_4}{R_3 + R_4} \right) E_{ad} \dots\dots\dots (2)$$

$$\frac{1}{1 + \frac{R_1}{R_2} + \frac{C_2}{C_1}} = \frac{R_4}{R_3 + R_4} > \frac{1}{A} \dots\dots\dots (3)$$

The circuit oscillates stably when the below condition is satisfied.

$$\frac{1}{1 + \frac{R_1}{R_2} + \frac{C_2}{C_1}} - \frac{R_4}{R_3 + R_4} = \frac{1}{A} \dots\dots\dots (4)$$

It is very difficult for the circuit of Fig. 2 to satisfy constantly the condition of equation (4). Oscillation will not start if the condition of equation (4) is satisfied from the beginning. The conditions of oscillation are determined by equations (1) and (3), and they are not related with the oscillation amplitude. Therefore, the condition of equation (3) must be maintained until the oscillation builds up to the required amplitude and, then, the circuit must satisfy the condition of equation (4). To accomplish this requirement, the resistance of R3 or R4 must automatically vary in response to the oscillation amplitude. This is accomplished by using a thermistor as for R3.

5. MAINTENANCE

5.1 CHASSIS INSPECTION

To gain access to the chassis, remove one screw in the center of the rear panel and two screws from the bottom of housing (now the rear panel can be removed) and pull out the chassis from the housing.

Fig. 3

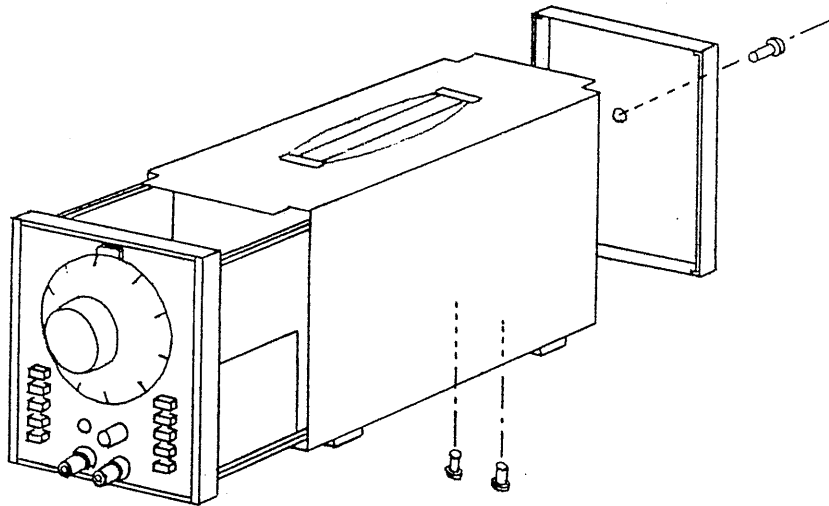
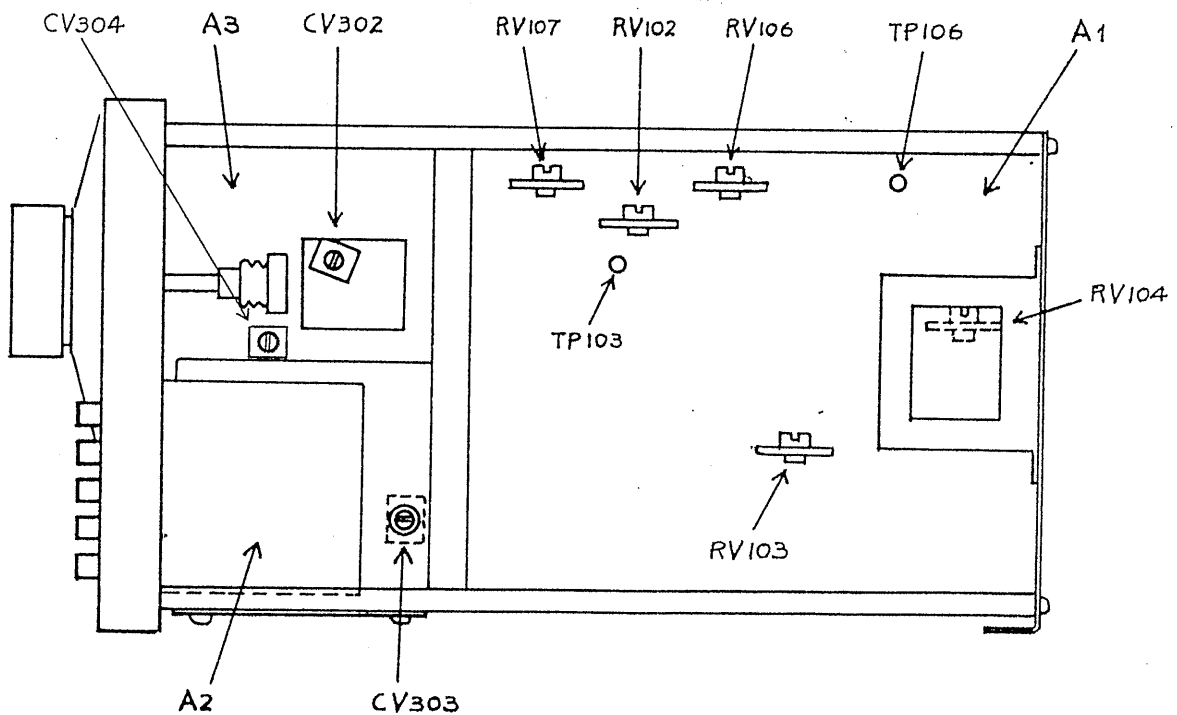

Fig. 4 Locations of controls and components



The electronic circuits of the Oscillator are fabricated on three printed boards. Location of controls (trimmer capacitors and semi-fixed resistors) are shown in Fig. 4.

- A1: Oscillator, Schmitt circuit, output amplifier, and power supply
- A2: Output attenuator
- A3: Wien bridge circuit
- CV302: Frequency adjustment of X100 and X1K range
- CV303: Frequency X100K range
- CV304: Frequency X10 range
- RV102:)
- RV106:) Oscillator circuit DC balance adjustment
- RV107:)
- RV103: Schmitt circuit, waveform symmetry adjustment of square wave
- RV104: Voltage adjustment of +40V supply

5.2 ADJUSTMENTS

Referring to Fig. 4, make adjustments as below.

(1) DC Supply Voltage (+40 V) Adjustment

Adjust the voltage as measured at TP106 of printed board A1 to $+40\text{ V} \pm 0.5\text{ V}$ by means of semi-fixed resistor RV104.

(2) Oscillator DC Balance Adjustment

Connect the gate of FET Q101 MK-10 to the ground terminal before adjusting, using the wire which is less than 30 CM. Adjust the voltage as measured at TP103 of printed board A1 to $+19\text{ V} \pm 0.3\text{ V}$ by means of semi-fixed resistor RV102.

(This adjustment must be performed patiently because the response is slow as a large capacitor is connected in this circuit.)

(3) Waveform Symmetry Adjustment of Square Wave

Press the "X1K" button of the FREQ RANGE selector and the SQUARE button of the waveform selector. Observing the output with an oscilloscope, adjust the output waveform by means of semi-fixed resistor RV103 so that dimensions A and B illustrated below are made equal.

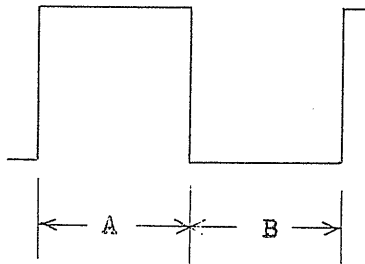

(4) Frequency Adjustment

i) FREQ dial position setting

Measure the frequencies corresponding to "1" position of the FREQ dial and the FREQ RANGE buttons of X100, X1K, and X10K (100 Hz, 1 KHz, and 10 KHz, respectively). Adjust the FREQ dial to the position where the errors are made minimum, and fix the dial in this position.

ii) Set the FREQ dial in the "10" position and press the "X1 K" range button, and adjust CV302 so that the oscillation frequency is made 10,00 KHz. In a similar manner, press the "X100 K" range button and adjust CV303 so that the frequency is made 1000 KHz.

iii) Keeping the FREQ dial in the "10" position and pressing the "10" range button, adjust CV304 so that the oscillation frequency is made 100.0 Hz.